

FABRICATION MANUAL



SURFACES
— BY PACIFIC —

Elevating Spaces. Enriching Lives

2026



Reproduction, storage, or transmission of any part of this work, in any form—graphic, electronic, or mechanical—is prohibited without written consent from Surfaces by Pacific

This guide replaces all previous versions and may be updated without prior notice. For the latest version, please visit the Surfaces by Pacific website or contact your representative.

Contents

1. Introduction

2. General Safety

3. Slab Information

3.1 Slab Data

4. Handling, Transportation & Storage

4.1 Handling

4.1.1 Lifting Methods

4.2 Transportation

4.3 Storage

4.3.1 RackStorageon Angled Posts

4.3.2 Storage on A-

Frames 4.3.3

Dangerous Storage

5. Visual Slab Inspection

5.1 Inspection Process

5.2 Color Matching

5.3 Samples vs. Full Slabs

6. Tools and Machinery

6.1 Required Equipment

6.2 Wet Cutting Machinery

6.3 Optional Automated Machinery

6.4 Required Tools

6.5 Installation Accessories

6.6 Adhesives

7. Pre-Fabrication

7.2 Measuring

7.2.1 Measuring by Template

7.2.2 Measuring by Dimension

7.2.3 Measuring UsingElectronics

7.3 Slab Optimization

7.4 Positioning Joins

8. Fabrication

8.1 Cutting the Slab

8.1.1 Full Body Cutting Considerations

8.1.2 Cutting Straight Lines

8.1.3 Cutting Curved Lines

8.1.4 Cutting Holes

8.2 Seams 8.3 Cutouts

8.3.1 Fabricating Cutouts for Fixtures

8.4 Fabricating Edges

8.4.1 Single Thickness Edges

8.4.2 Laminated Edges

8.4.3 Multilayered Edges

8.4.4 Miter Edges

8.5 Polishing Edges

8.5.1 Polished Finishes

8.5.2 Concrete, Honed/Matt, and Natural Finishes

8.5.3 Rough Concrete Finishes

8.6 Support Strips

9. Installation

9.1 Preparing the Base Units/Cabinets

9.2 Countertops

9.2.1 Preparation for Installation

9.2.2 Seaming

9.2.3 Sealing Between the Surface and the Wall

9.2.4 Attaching Surfaces by Pacific to Cabinets

9.3 Sinks

9.4 Cooktops/Hobs

9.5 Utility Rooms

9.6 Accessories

9.6.1 Attaching Accessories Mechanically 9.6.2 Attaching Accessories with Adhesive

9.7 Overhangs

9.8 Tabletops

9.9 Finishing

Touches

10. Care & Maintenance

10.1 Stain Removal for Fabricators

11. Environment, Standards & Certificates

12. Disclaimer

1.Introduction



Surfaces by Pacific' are perfect for various interior commercial and residential applications, such as kitchen countertops, bathrooms, bartops, vanities, reception counters, and furniture.

These surfaces are not suitable for exterior use or areas exposed to UV radiation or excessive heat.

Our quartz surfaces come in a wide range of colors, organized into different series with distinct properties.

Manufactured from up to 90% quartz—one of nature's hardest minerals—combined with high-quality polymer resins and pigments, our surfaces are compacted under intense vibration, vacuum, and pressure into dense, non-porous slabs. The slabs are then post-cured, gauged to different thicknesses, and polished to achieve a smooth finish.





2. General Safety

PacificEngineeredSurfaces is committed to maintaining a safe work environment and expects the same dedication from our distributors, fabricators, and installers. Compliance with local occupational, safety, and health regulations is required.

Fabrication of Surfaces by Pacific can generate respirable dust, which poses health risks.

HOUSEKEEPING

Keep your work area clean and organized. Regularly monitor housekeeping practices to prevent hazards associated with a cluttered environment.

VENTILATION

Ensure working areas are well-ventilated and adequately lit.

AUTHORIZED PERSONNEL ONLY

Limit access to the work area to authorized personnel only.

PROPER FOOTING

Avoid overreaching. Maintain proper footing and balance at all times.

FIRST-AID KIT

Ensure a fully equipped first-aid kit, suitable for the tasks being performed, is available on-site at all times.

READ INSTRUCTIONS

Familiarize yourself with the instruction manuals for the tools being used. Understand their application, maintenance, limitations, and potential hazards.

USE APPROPRIATE TOOLS

Use tools and attachments as recommended by the manufacturer. Avoid using tools or attachments for purposes or at speeds for which they were not designed, and do not use improvised tools.

MAINTAIN TOOLS

Keep all tools in good working condition, and have them tested or serviced according to the manufacturer's recommendations.

Protective Apparel for Fabricating Surfaces by Pacific



HELMET & HAIR COVERING

Wear a hair covering to manage long hair and a safety helmet during handling and transporting.



HEARING PROTECTION

Use appropriate hearing protection in noisy environments.



RESPIRATORY PROTECTIVE EQUIPMENT (RPE)

Wear a disposable dust mask with P3/N95 filters, a fit-tested half-face respirator with P3/N95 filters or higher, or a Powered Air Purifying Respirator (PAPR). The RPE should be suitable for the working conditions and comply with all relevant standards and regulations. Workers with facial hair should use a PAPR.



SAFETY GOGGLES

Protect your eyes with safety glasses or other approved eye protection.



GLOVES

Use gloves to protect against chemicals or rough materials.



SAFETY SHOES

Wear nonslip, steel-capped safety shoes. In wet areas, steel-capped rubber boots should be used in addition to the above.

GFCI

All electrical tools must have a Ground Fault Circuit Interrupter (GFCI) or Residual Current Device (RCD). Ensure three-prong plugs are used with three-hole electrical sockets. If an adapter is needed for a two-prong socket, it must be grounded. Never remove the third prong from plugs.

OPERATE TOOLS SAFELY

Use clamps or a vise to secure workpieces when needed, allowing both hands to operate tools safely. Ensure that all portable and fixed tools have proper guarding in place.

REMOVE KEYS

Always remove keys and wrenches before operating tools. Verify that keys and adjusting wrenches are not left on or near the tool before switching it on.

DO NOT WEAR JEWELRY

Avoid wearing neckties, rings, bracelets, or other jewelry that could become entangled in moving parts.



3. Slab Information

3.1 Slab Data

The slab dimensions provided are for storage and transportation purposes only. The actual usable surface area is slightly smaller on each side because of the beveled edges.

SUPER JUMBO SLABS

DIMENSIONS

LENGTH	3480 mm(137")
WIDTH	2010 mm(79")
THICKNESS	12mm 20mm 30mm

WEIGHT

	k g	lb
30mm	500 - 530 kg	1102 - 1169 lb
20mm	295 - 330 kg	650 - 728 lb
12mm	175 - 200 kg	386 - 441 lb

12 mm slabs are available in selected colors.

Note: Imperial measurements in this manual are approximate only.

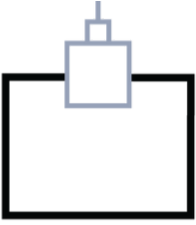

4. Handling, Transportation & Storage

Throughout handling, transportation, and storage, ensure slabs are balanced to their center of gravity. Follow all relevant safety regulations concerning equipment and personnel.

4.1 Handling

PacificEngineered Surfaces slabs should be loaded, unloaded, and transported using a forklift, bridge crane, or other suitable lifting devices.

ENGINEER'S APPROVAL

Ensure that all lifting tools and equipment are inspected and approved by an engineer specializing in lifting and handling. The engineer must confirm that the equipment is in good working order and suitable for the load's weight and purpose.

ARRANGING SLABS

When lifting multiple slabs in a single load, arrange them back-to-back with no gaps between them.

PREFERRED ACCESSORIES

Use clamps or straps as the preferred accessories for securing slabs to the lifting device.

4.1.1 Lifting Methods

When lifting slabs, observe the following precautions:

- **Slow Lifting and Securing:** When using a scissor lifter or clamp lifter, begin lifting the slabs slowly. Ensure they are firmly secured before proceeding with transportation.
- **No Modifications:** Do not alter the clamps or other lifting mechanisms in any way.
- **Adhere to Load Capacity:** Never exceed the load-lifting capacity of the lifting equipment.

When lifting or transporting slabs, ensure you use the appropriate lifting equipment that is certified with safe work load limits. Follow one of the methods below for lifting the slabs:

LIFTING STRAPS

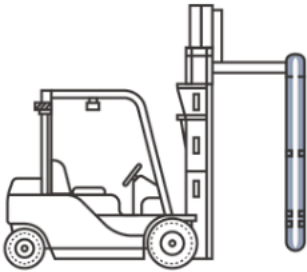

SCISSOR LIFTER

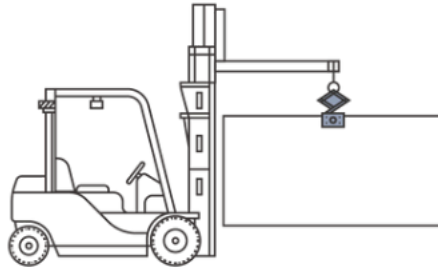

CLAMP LIFTER

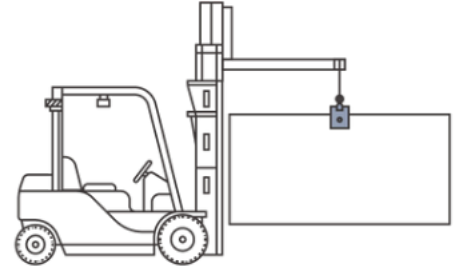

VACUM LIFTER

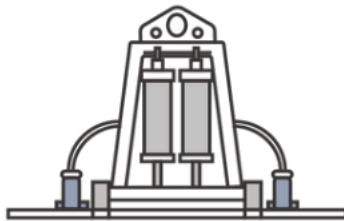

CRANE & SPREADER BEAM

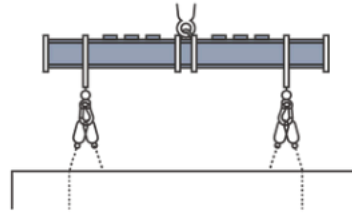

Proper Use of Clamps

- Ensure the slabs are correctly positioned in the clamps, as shown in the diagram. Incorrect placement can cause the slabs to fall or damage the lifter.
- Some clamps are designed to lift multiple slabs simultaneously, depending on the clamp size.
- Do not lift multiple slabs if they are not of the same height.

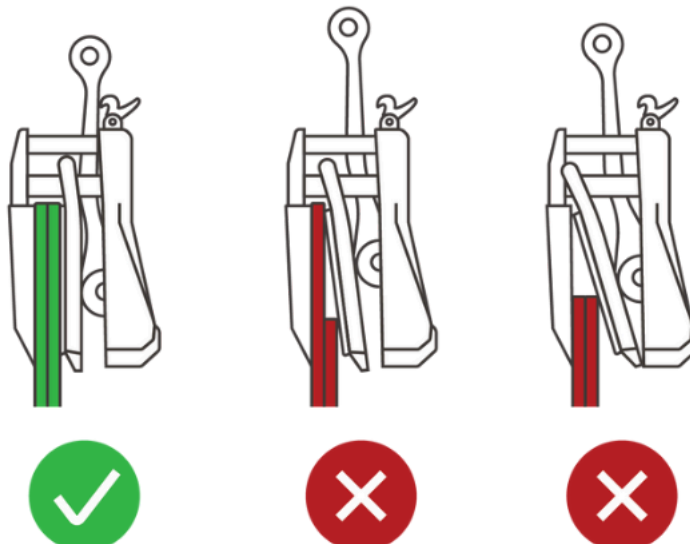

4.2 Transportation

Surfaces by Pacific slabs can exceed 300 kg (661 lb) per slab. All vehicles used for transporting these slabs must be designed to handle such weight and ensure safe transport. Refer to the diagrams below for guidance.

- **Frame Attachment:** Securely attach a suitable, approved frame, such as an A-frame, to the truck. Ensure the frame has no visible defects.
- **Securing Slabs:** Make sure the A-frame is firmly secured to the vehicle and that the slabs are properly fastened to the A-frame to prevent movement during transport.
- **Load Distribution:** Load slabs evenly on both sides of the frame, positioning them face-to-face and back-to-back without gaps.
- **Strapping:** Use load-rated straps or ratchet tie-downs to secure the load. Replace straps at the first signs of wear.

Avoid using rope, as it degrades quickly and lacks the necessary stability.

- **Protection:** Place protective strips between the straps and the edges of the slabs to prevent abrasion and damage.
- **Load Containment:** Ensure the load remains entirely within the vehicle's tray to prevent any broken slabs from falling onto the road and posing a hazard to other road users.

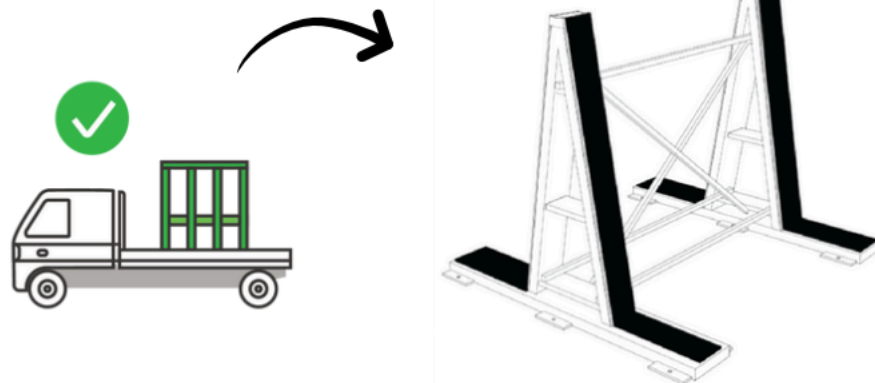

Transportation of Fabricated Surfaces

Proper racking is crucial for transporting fabricated pieces to the site in excellent condition. Follow these specific instructions in addition to the general guidelines:

Protective Layer: Ensure a protective layer is placed between the rack and the fabricated pieces to prevent scratching or other damage during transit.

Arranging Fabricated Pieces: Position the fabricated pieces on the rack face-to-face and back-to-back, with no gaps. Each piece should be fully supported by the adjacent pieces. Place pieces with cutouts in the center of the stack, protected by solid pieces. Consider

using a protective layer between cut pieces of different sizes to avoid abrasion.

Secure the Slabs: Use appropriate, load-rated securing devices to safely fasten the slabs.



Driver Responsibilities

Drivers must remain with their vehicles and ensure the following:

- **Vehicle Condition:** The vehicle must be in good working order and condition.
- **Load Capacity:** Confirm that the load, including any partial loads, is within the vehicle's legal carrying capacity before loading the Surfaces by Pacific slabs.
- **Correct Slabs:** Verify that the correct slabs are loaded onto the vehicle.
- **Load Security:** Ensure the load is fully supported and securely fastened to the vehicle before departing from the premises.

4.3 Storage

4.3.1 Rack Storage on Angled Posts

The diagrams below illustrate the recommended storage method for Surfaces by Pacific slabs.

These slabs are heavy and can pose serious risks if not stored safely and securely. Ensure all slabs are properly secured to prevent them from falling during storage and transportation.

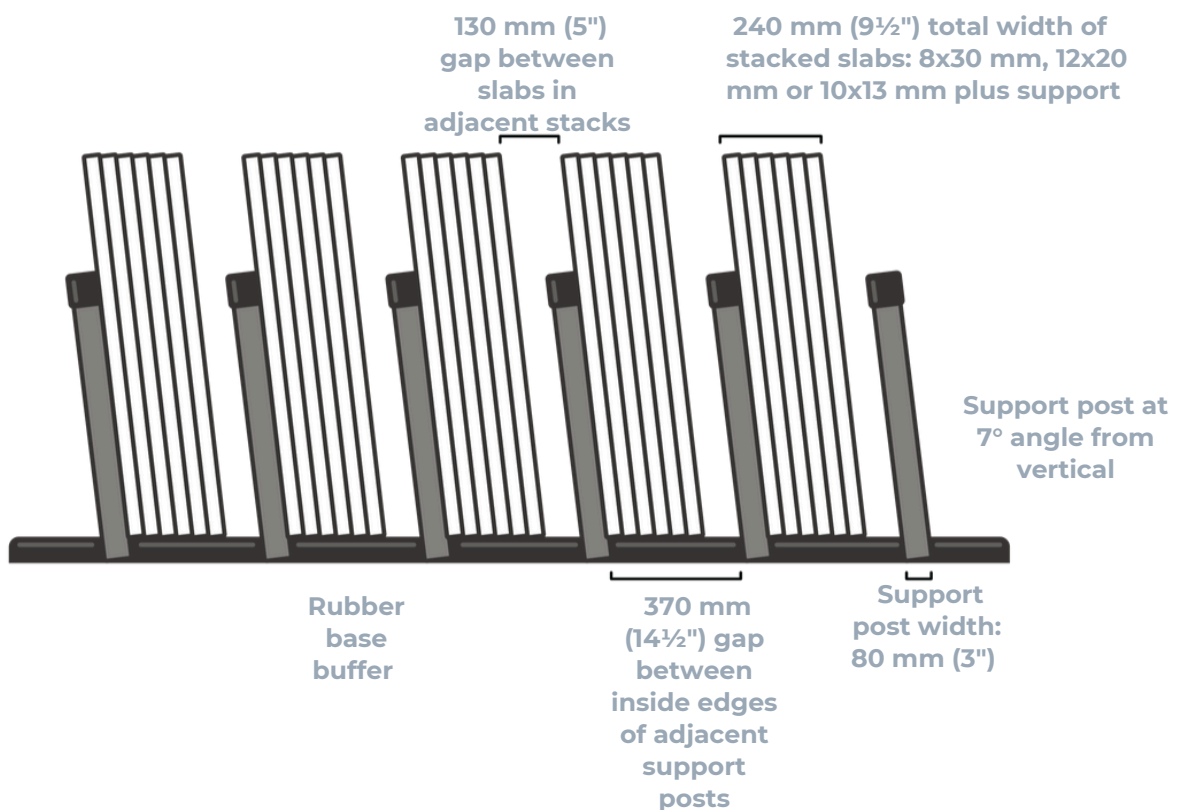
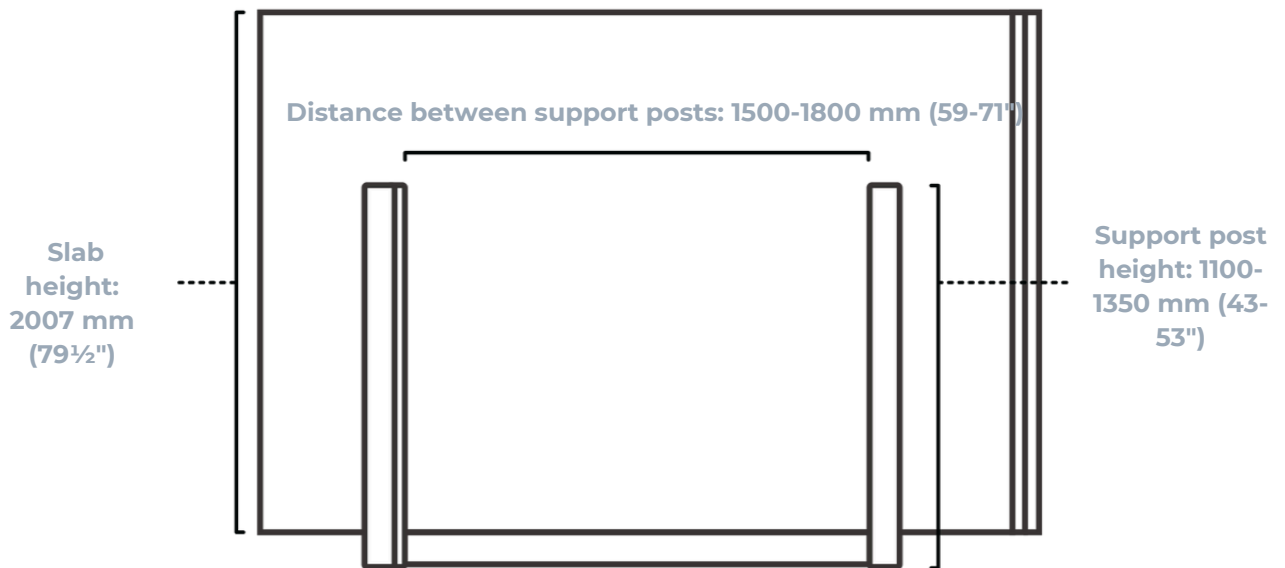

Maximum Slabs in a Stack

- The maximum number of slabs allowed in a stack:
 - 8 slabs for 30 mm
 - thickness 12 slabs for 20 mm thickness

Support Posts

- Use at least two support posts, spaced 1500-1800 mm (59-71 inches) apart, to support the slabs. Ensure the slab is centrally positioned and fully in contact with the entire height of the posts.

Store Under Cover

- Surfaces by Pacific recommends always storing slabs under cover.

Additional Support in High Temperatures

- If slabs are stored in sunlight or high-temperature areas, provide additional support to prevent warping. This can be done by adding a third post or placing a 30 mm thick slab against the posts.

Do Not Expose the Polished Surface

- Store the outer slabs in each rack with their backs facing outward to protect the polished surface.

Easy Identification

- Store slabs face-to-face and back-to-back with no gaps, allowing easy identification of color and batch numbers.

Cut Slabs

- Avoid storing cut slabs between full slabs.

Rubber Buffers

- Surfaces by Pacific recommends placing rubber buffers at the base of the stand to prevent chipping.

4.3.2 Storage on A-Frames

Slabs can be safely stored between the uprights of A-frames. While this setup is safer than using open-ended A-frames, it is not ideal and should only be used as a temporary storage solution.

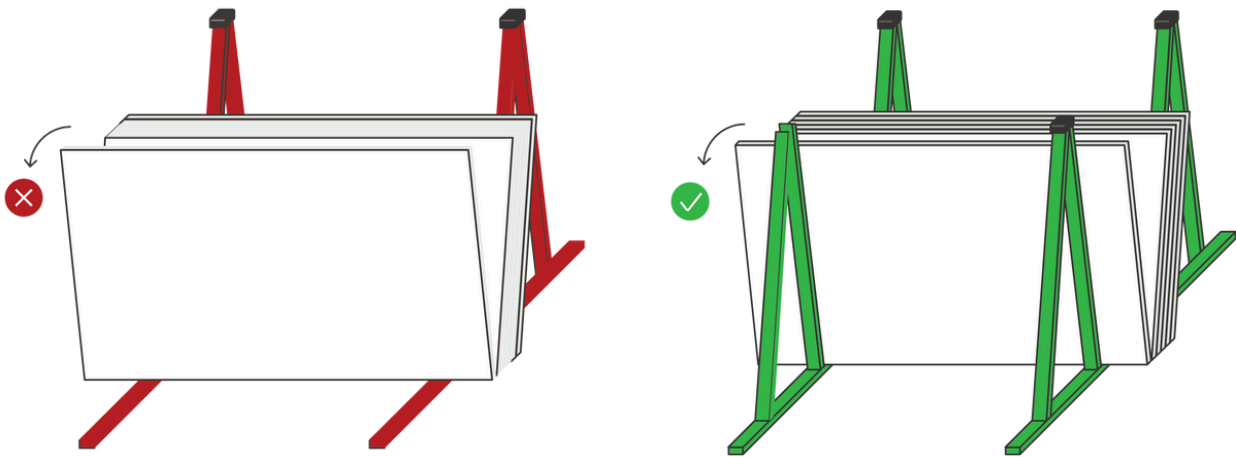

Do not store slabs on the open ends of A-frames, as there is a danger of the slabs falling if tilted too far.

Do not stand between the slabs; always control the slabs from the outside.

The angle of the frames allows an operator to pry the slabs apart to insert a lifting clamp. However, if pulled too far, the slabs will reach a point of no return and can no longer be controlled by the operator.

20 mm slabs weigh up to 325 kg (716 lb) and 30 mm slabs weigh up to 425 kg (936 lb). Once these start to tip over, it is unlikely that the operator will be able to stop them, which could lead to him being crushed.

4.3.3 Dangerous Storage

This picture shows a dangerous working environment. There are numerous safety issues that could lead to serious injury, such as:

- No outer support post Uneven
- ground
- No rubber base buffer

In addition, several issues here may damage the slabs:

- Cut pieces placed against or between whole slabs may scratch
- the slabs The polished surface exposed to sunlight may fade
- Unsecured slabs may fall and break
- Incomplete support may cause warping



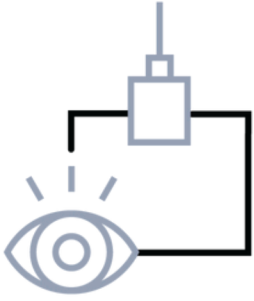

5. Visual Slab Inspection

5.1 Inspection Process

It is essential to visually inspect both the front and back of all slabs, including the perimeter, for imperfections before cutting.

Remove Plastic Coating

Surfaces by Pacific covers all slabs with a protective plastic coating. Remove the coating and label to perform a thorough visual inspection.

Inspect with Light

Ensure that the slab is inspected under appropriate lighting, whether natural or artificial.

Check from Various Angles

Examine the slab surface from different angles, including eye level, to detect any issues that might not be visible when viewed from above.



FABRICATOR RESPONSIBILITY

Fabricators should conduct the following visual inspections to identify any imperfections and assess whether the slab is suitable for the intended job layout. If a fabricator determines that a slab is not fit for use due to any of the listed imperfections, they should promptly contact Surfaces by Pacific. Only slabs that have not been cut or altered in any way will be considered for replacement. Surfaces by Pacific reserves the right to make the final decision.

Perform the following visual inspections for imperfections:

- Cracks, pits, voids
- Inconsistent gloss levels
- Polishing marks
- Thickness tolerance of ± 1 mm
- Warping: up to 3 mm in length and 2 mm in width when the slab is horizontal and fully supported

Check for warping by using a full-length straight edge with the slab in a horizontal position.

Surfaces by Pacific quartz surfaces are crafted from natural materials. Variations such as irregular spots, color inconsistency, or quartz pattern irregularity within a slab are inherent to the manufacturing process and are considered natural characteristics of the material.



5.2 Color Matching

Surfaces by Pacific slabs contain up to 90% natural quartz. Due to this, slight color and aggregate variations may occur between slabs and across different production cycles.

BATCH NUMBER

- Each production cycle is assigned a unique batch number.
- The batch number can be found on the label attached to all slabs and is also stamped on the back of the slab.



Use slabs from the same batch for each job to ensure color consistency. However, always perform a visual color match before cutting to verify uniformity in shading

5.3 Samples vs. Full Slabs

While a sample provides a good indication of the slab's look and feel, it may not fully represent the overall effect of the full-size slab.

CONFIRM WITH CLIENT

We always recommend that customers view the full slab image, or the actual slab if available, before fabrication to ensure it meets their expectations and to avoid any issues at the time of installation. Our website visualizer allows customers to view full slabs.





6. Tools and Machinery

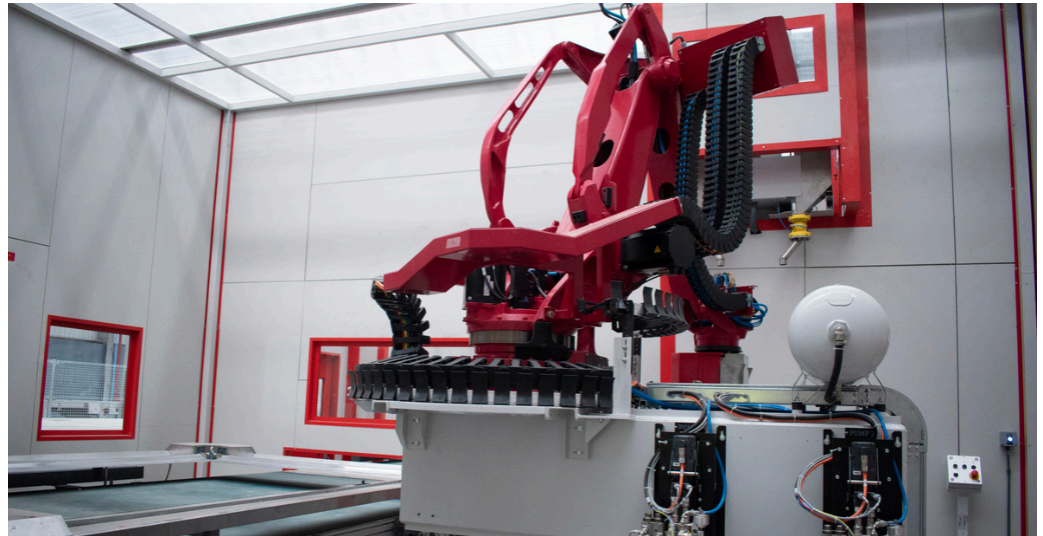

6.1 Required Equipment

- General ventilationsystem
- Local exhaust
- ventilation Water
- recycling system
- Forklift or other lifting device
- Fabrication workbenches in various sizes
- Stone carts/dollies
- Storage racks or A-frame

6.2 Wet Cutting Machinery

One of the following is required for cutting slabs:

- Combined waterjet and diamond blade saw (CNC)
- Waterjet (CNC)
- Automated bridge saw (CNC)

6.3 Optional Automated Machinery

- Edge profiling
- machine Slab polishing machine

6.4 Required Tools

- Heavy-duty electric/pneumatic angle grinder for cutting or grinding (variable speed preferred)
- Light electric/pneumatic angle grinder for polishing (variable speed preferred)
- Pneumatic polisher
- Diamond cutting disks in various sizes
- Diamond contour blades
- Diamond core bits in various diameters
- Diamond grinding wheel
- Shaped grinding wheel
- Wet edge profiling machine (edge router)
- Electric hand drill (variable speed preferred) Carbide-tipped drill bits
- Polishing drums for inside corners
- Sets of diamond and sanding polishing pads
- Diamond polishing brushes (refer to section 8.5.3)
- Various sizes of clamps
- Grinding stone
- Pneumatic seam setter

Consult your local distributor to choose the appropriate diamond tools for cutting Surfaces by Pacific slabs.



6.5 Installation Accessories

- Dustcollection installation tools
- Vacuum cleaner with HEPA filter for dust collection
- Seaming clamps
- Pigments (for tinting seam adhesive)
- Cleaning materials
- Spatula and scraper
- Quartz granules (for repairs; contact your Surfaces by Pacific representative)



6.6 Adhesives

To join two pieces of Surfaces by Pacific quartz, use either polyester resin adhesive or epoxy-modified acrylic. Suitable adhesives that match the quartz's color range include Tenax®, Impa®, Akemi®, and Integra®.

Important Notes:

- These adhesive recommendations do not apply to the Surfaces by Pacific Outdoor product.
- Color-matched adhesives might require shade adjustment due to minor variations between different batches of quartz slabs.
- Adding transparent adhesive to the color-matched adhesive can improve its properties.
- To ensure a minimally visible seam, the adhesive color should match the surface color closely. If a pre-colored adhesive is not available, mix color paste pigments with the adhesive.
- Note that the color may appear slightly lighter after drying.

To join Surfaces by Pacific quartz to other materials, use a flexible adhesive such as 100% silicone or polyurethane-based adhesives that are compatible with both the quartz and the other material.

Reminder: Always read and follow the adhesive manufacturers' instructions, including safety guidelines.





7. Pre-Fabrication

7.1 Planning

CHECK THE SUBSTRATE

Ensure the substrate (such as the kitchen cabinet for a kitchen countertop) is in its final location, level, and ready for the surface installation.

SIZE, SHAPE, AND LOCATION

Plan the dimensions, shape, and placement of the surface pieces. Refer to section 7.4 for considerations on join placements.

MINIMIZE WASTAGE

To reduce slab wastage, plan the fabrication of rectangular pieces whenever possible.

ALLOW FOR REMOVAL OF PERIMETER

Consider that a minimal portion of the outer perimeter of the slab will need to be removed to straighten the edges.

7.2 Measuring

MEASURING METHODS

The three most common methods of measuring are: by template; by dimension; and by electronic devices as described in sections 7.2.1, 7.2.2 and 7.2.3.

7.2.1 Measuring by Template

- **Mark Seams:** Indicate seam locations on the cabinets.
- **Construct Template:** Create a solid or frame template for each surface piece.
- **Mark Installation Points:** Mark center points for items like sinks and cooktops/hobs on the template.
- **Verify Placement and Space:** Ensure proper alignment with the surrounding area for items.
- **Include Fabrication Information:** Note details such as edges needing polishing on the template.
- **Control Measurements:** Confirm angles, dimensions, and arrangement of cut pieces with control measurements.
- **Transfer Measurements:** Transfer measurements to the slab by tracing the template or using an industrial scanner.

Constructing a Solid Template

Surfaces by Pacific recommends constructing solid templates using polypropylene sheets cut to size, as follows:

- Place the polypropylene sheets on the cabinet.
- Align the edges of the sheet with the seam lines and the edge of the cabinet or wall.
- Cut the template to the required external shape and dimensions, including overhangs and space for circumferential gaps.
- Join two or more sheets of polypropylene if needed to achieve the correct size and shape for each part of the template.
- Avoid using cardboard for templates, as it is easily damaged and distorted.

Constructing a Frame Template

Construct a frame template using any light, stable, rigid material, such as plastic strips approximately 70-100 mm (2¾-4") wide and 3-4 mm (¼") thick:

- Position length strips along the surface piece, including overhangs and space for circumferential gaps, aligning the ends with the seams marked on the cabinet.
- Glue width strips approximately every 300-400 mm (12-16") across the width of the template using rapid-drying adhesive, ensuring the end strips align with the seams marked on the cabinet.

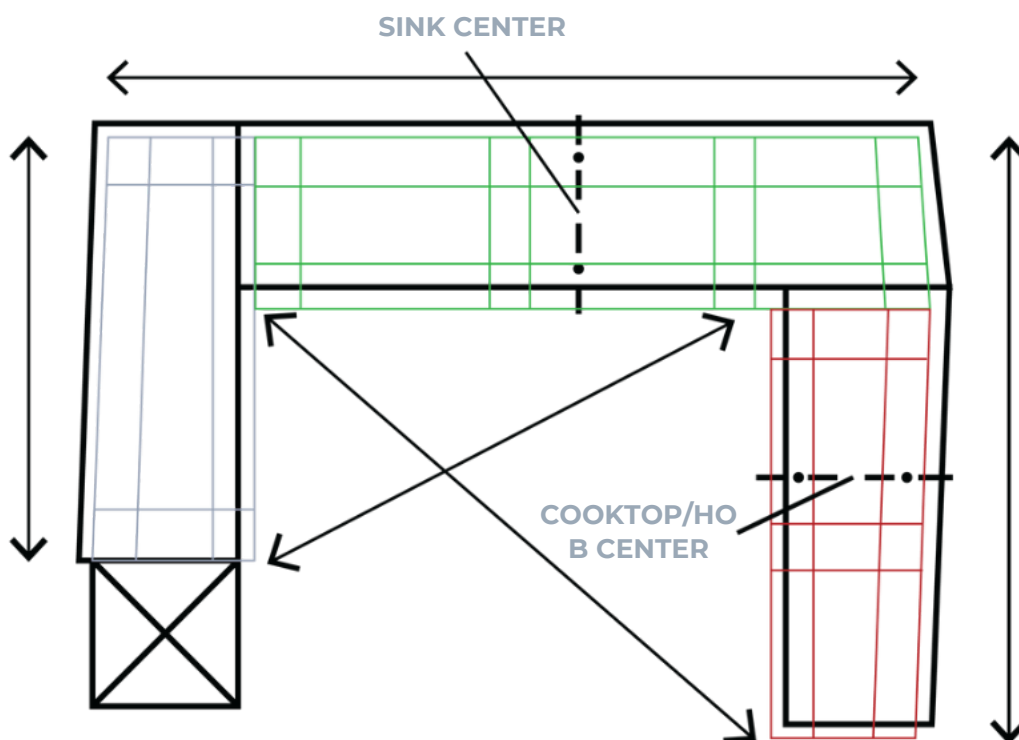

Example of template

7.2.2 Measuring by Dimension

- Create a clear diagram to record measurements, preferably using a computer or a professional drawing board with a ruler.
- Use the front line of the installation as the central line on the diagram for all measurements. If the front line is not perfectly straight, draw a straight line on the cabinet to serve as the central line. Mark the center points for items to be installed in the countertop, such as sinks and cooktops/hobs, on the diagram.
- Verify that the total dimensions of one side match the length of the entire side.
- Avoid assuming that corners are exactly 90°. Measure the sides or use an angle gauge, as a 1° deviation in a 90° angle can result in a deviation of 52 mm per 3 m (2" per 118").

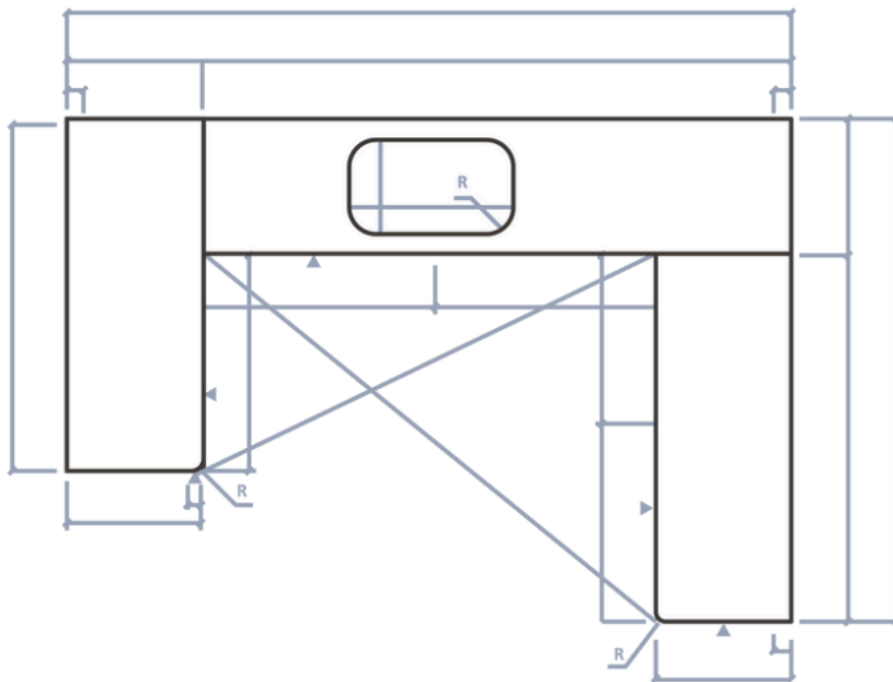

Measuring can also be done using a laser, which is automatically converted by computer software into a work plan.

7.2.3 Measuring Using Electronics

Advanced electronic measurements that produce CAD files can be performed using technologies such as e-templating, Proliner®, and LT-2D3DTM Laser Templators.* These technologies offer significant advantages for fabricators using CAD files with automated equipment like CNCs and Water Jet cutting.

- Only trained personnel should operate this equipment, and several dimensions should be checked manually to ensure proper functionality.
- Record all critical points to enable accurate file creation, and the trained operator must include details such as overhangs, radii, and sink locations.
- Clearly indicate and define finished edges.
- These units typically provide accuracy within 2 mm (1/16"), but a knowledgeable person should be present on-site to address installation challenges.



7.3 Slab Optimization

MINIMIZE WASTAGE:

- Plan the arrangement of the pieces to be cut from the slab to reduce wastage. Consider that a small portion of the outer perimeter of the slab will need to be removed to straighten the edges.

CHECK FLATNESS:

- Verify the flatness of the surface at locations planned for seams.

VISUAL CONSISTENCY:

- When cutting slabs, align the ends cut from adjoining sections of the same slab to maintain the best match for quartz distribution, pattern arrangement, and color consistency. This is especially important in areas with high reflected light.

SLAB ORIENTATION CONSISTENCY:

- For extra-long benchtops, add an extension piece to the end of the primary slab. It is highly recommended that this extension piece be cut from a slab oriented the same way as the primary slab.

Example of plan of slab pieces

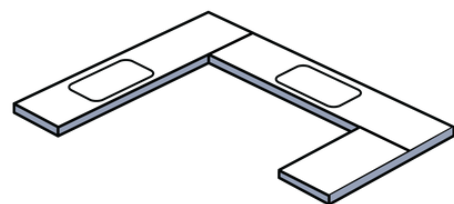
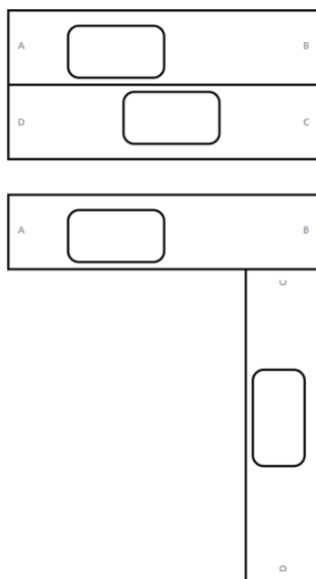

7.4 Positioning Joints

Surfaces by Pacific recommends fabricating a straight joint for each change of direction in the countertop (see figure 1). Countertops without joints are more susceptible to cracking during transportation, installation, and post-installation.

- For single thickness countertops without a joint, the inside corner must have a minimum 10 mm (3/8") radius (see figure 2). A larger radius increases the strength of the corner. Fabricating a 90° angle on an inside corner is not recommended (see figure 3).

Cracking does not indicate a material fault but results from externally induced mechanical stress on the countertops. The most common causes are heat (thermal shock) leading to expansion or contraction, or high point loads.

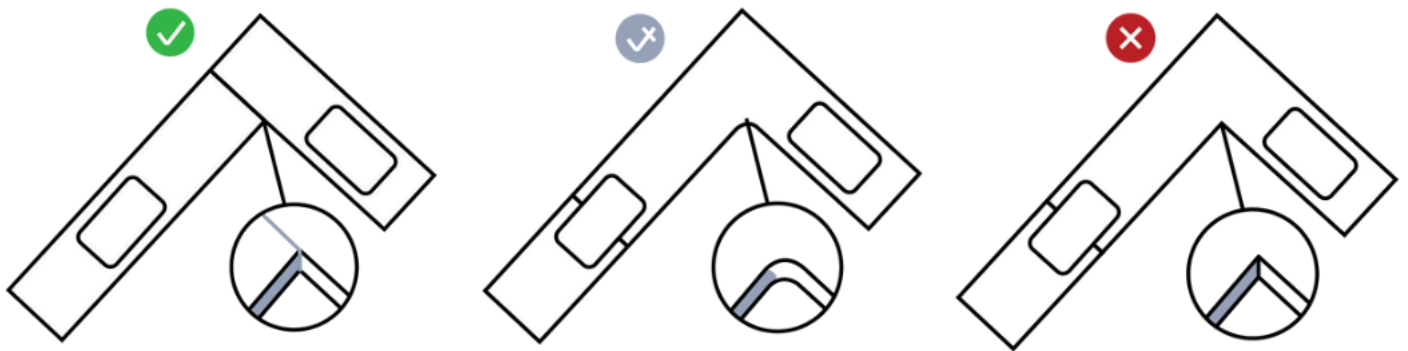

Diagonal Joins

Surfaces by Pacific recommends using diagonal joins only when necessary to continue veins or patterns in the slab (see figure below).

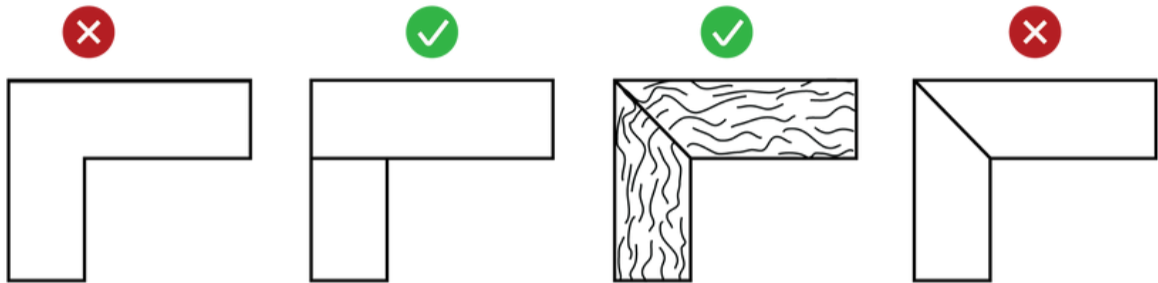



8. Fabrication

8.1 Cutting the Slab

Important: Use only water-cooled tools for cutting, drilling, and polishing to prevent overheating and dust generation. Dry cutting Surfaces by Pacific quartz can damage its physical properties, making it more prone to cracking, chipping, discoloration, and other issues. Problems resulting from dry cutting are not covered by the Surfaces by Pacific warranty.

- **REMOVE SLAB PERIMETER:**

Before cutting according to plan, trim a minimal amount off the outer perimeter of the slab to straighten the edges.

- **CHECK COLOR MATCH:**

Ensure the color match of the pieces to be seamed before cutting the slab.

- **MAINTAIN TOOLS:**

Use a silica stone to keep diamond cutting tools sharp.

8.1.1 Full Body Cutting Considerations

Surfaces by Pacific slabs are full body, meaning the materials are integral to the entire slab rather than just a surface layer or printed on top.

- The veins in Surfaces by Pacific slabs are not intended to extend through the full depth of the slab. While some veins may reach the back of 20 mm slabs, this is not consistent across all slabs, so applications should not assume this capability.
- If it is necessary for the design to be visible on both sides of the slab, we recommend joining two slabs with the top surfaces facing outwards.

We do not recommend polishing the back of slabs as the factory-polished side can easily be damaged during the process.

8.1.2 Cutting Straight Lines

- **AUTOMATED:**

Machine cut straight lines using a CNC.

- **TOOLING:**

Ensure you use the correct diameter diamond disk for the machine and material.

8.1.3 Cutting Curved Lines

- **AUTOMATED:**

Machine cut curved lines using one of the following methods:

- CNC with a water-cooled diamond
- finger bit Water jet cutter

- **MANUAL:**

Cut curved lines manually using one of the following methods:

- Router with a water-cooled diamond finger bit
- Grinding wheel with a water-cooled concave diamond disk



8.1.4 Cutting Holes

AUTOMATED:

- Machine cut holes using one of the following methods:
 - Drill with a water-cooled diamond
 - core bit CNC with a water-cooled
 - diamond core bit Water jet cutter

MANUAL:

- Cut holes manually using a carbide-tipped drill bit for small holes or a diamond core bit mounted on a water-cooled angle grinder or manual drill for larger holes.

8.2 Seams

- **BONDING AREA FOR ADHESIVE:**

Cut an X-shaped pattern approximately 1 mm (1/32") deep into the edges to be seamed to improve the bonding area for the adhesive.

- **SUPPORT STRIPS:**

Attach wooden support strips to the cabinetry beneath seams, ensuring that the center of the seam rests on the support strip.

- **SUPPORT IN AREAS OF HEAT:**

Use a full subdeck for additional support in areas exposed to heat.

Do not polish seams on Surfaces by Pacific.

Avoid using acetone on the surfaces; instead, use alcohol for cleaning during installation.

8.3 Cutouts

Cutouts are created in countertops for installing sinks, cooktops/hobs, and other fixtures.

- Follow the fixture manufacturer's instructions for creating cutouts.
- Fabricate a minimum radius of 10 mm ($\frac{3}{8}$ ") with a core bit or cup drill for all corners in cutouts, whether seen or unseen (see figure 1). A larger radius increases corner strength.
- If a 10 mm ($\frac{3}{8}$ ") radius cutout corner would interfere with the installation of an item requiring a 90° angle, drill beyond the corner with a core bit or cup drill (see figure 3).
- Avoid cutting beyond the rounded edge in cutouts as shown in figures 2 and 4, as this may cause hairline cracks.
- Do not cut square corners or cross cut corners (see figures 5 and 6).
- Do not cut a large radius in sections as shown in figure 7.

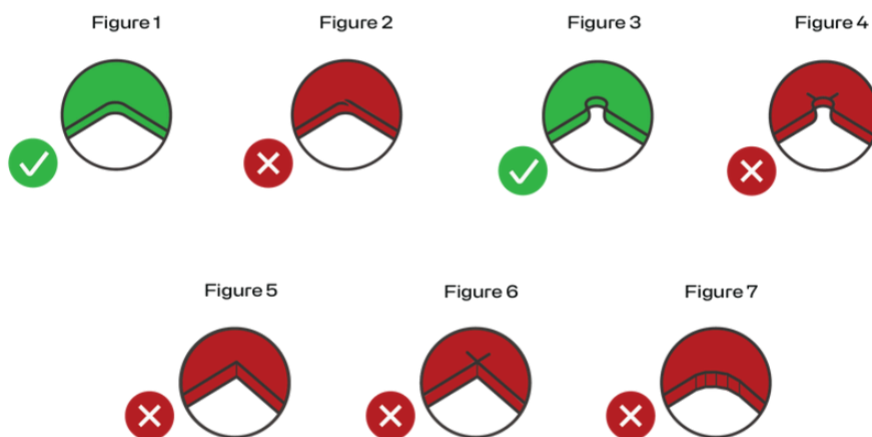

- Follow the manufacturer's instructions for cutouts, ensuring a minimum radius of 10 mm ($\frac{3}{8}$ ") for corners. If a 10 mm radius affects a 90° angle installation, drill beyond the corner.
- Do not reduce the surface thickness and maintain at least 60 mm ($2\frac{3}{8}$ ") distance from edges or seams. For distances less than 150 mm (6"), use a support strip from Surfaces by Pacific.
- Avoid overcutting, square or cross cut corners, and large radius sections.

8.3.1 Fabricating Cutouts for Fixtures

Install fixtures like sinks and cooktops/hobs by creating the appropriate cutouts in the countertop. Each type of fixture requires specific cutout fabrication methods.

Ensure the fixture is fully supported inside the cabinet with support rails or legs, in addition to being attached to the Surfaces by Pacific surface.

OVERMOUNT INSTALLATION:

For overmount installation, the lip of the cooktop/hob or sink rests above the surface. Smooth the edge of the cutout and leave it unpolished, ensuring a gap between the fixture wall and the surface.



FLUSH-TO-BOWL UNDERMOUNT INSTALLATION:

A flush-to-bowl cutout matches the inside wall of the sink, reducing the visibility of bonded edges but is challenging to produce precisely.



STEPPED BACK TO CURVE OR BEVEL OF BOWL INSTALLATION:

Some installations and templates require the counter's finished edge to be set back to the sink bowl's rounded or beveled top, minimizing visible flat deck of the sink.



OVERHANG INTO BOWL UNDERMOUNT INSTALLATION:

In undermount installation, position the sink underneath the surface. Fabricate the cutout slightly smaller than the sink aperture to hide the joint. Round or bevel the top and bottom edges, and polish them.



8.4 Fabricating Edges

VISIBLE EDGES:

Polish all visible edges to match the finish of the surface.

TOP OF EDGES:

Round or bevel the top of edges; avoid creating square edges.

MINIMUM EDGE PROFILE:

Ensure all edges have a minimum profile of 3 mm (1/8"). A larger edge surface increases resistance to chipping.

EDGE DETAILS:

Common edge details include radius or 45° bevel, but a wide range of options is available.

CONFIRM WITH CUSTOMER:

Visually confirm the edge profile with the customer before cutting, as terminology can vary by company and region.

8.4.1 Single Thickness Edges

Single thickness edges are the same thickness as the original slab.

- These edges are easily and quickly fabricated.
- Most automated edge profiling machines are designed for single thickness edges.

**Beveled edge 4-6 mm
(1/16-1/4")
recommended**

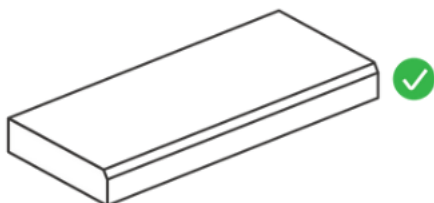

**Pencil round 4-6 mm
(1/16- 1/4") recommended**

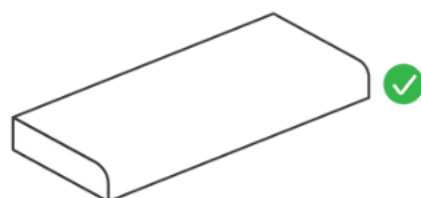

**Square edge not
recommended as
impact may cause
chipping**

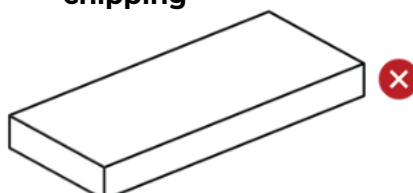

8.4.2 Laminated Edges

Lamination involves gluing one or more strips of Surfaces by Pacific to the bottom edge of another piece to create the appearance of a thicker slab.

This method is more complex and time-consuming compared to single-thickness edge fabrication.

Laminated edges provide a richer visual effect.

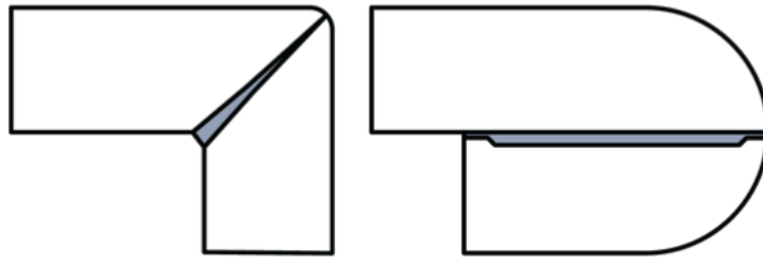

- **Color Match Lamination Strips**

Cut lamination strips from the same slab as the countertop, and whenever possible, from the same saw cut to ensure a color match.

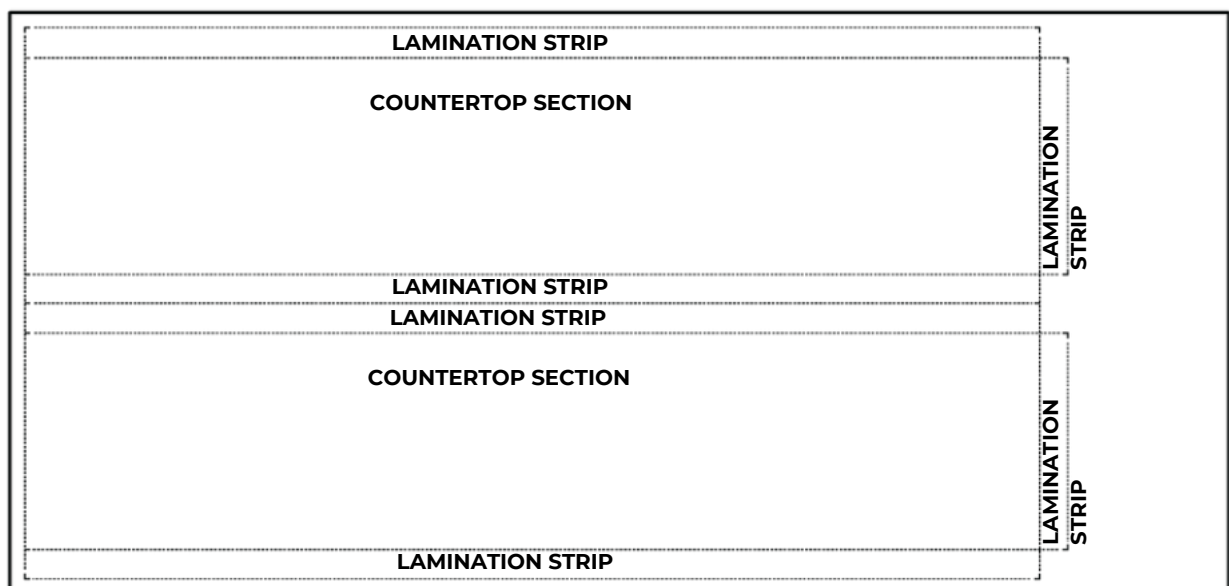

- **ALIGN JOINS WITH SEAMS**

The lamination strip should be the same length as the surface piece it is attached to, aligning the joins in the lamination strips with the surface seams.

- **MITER CUT EDGES**

The preferred method for laminating edges with longer skirts is the miter cut; see section 8.4.4.

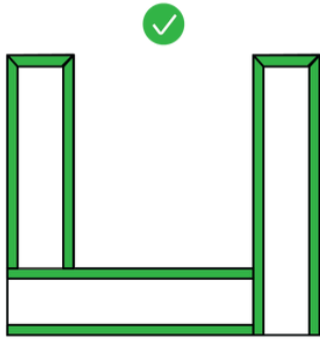

Underside of countertops showing correct positioning of lamination strips

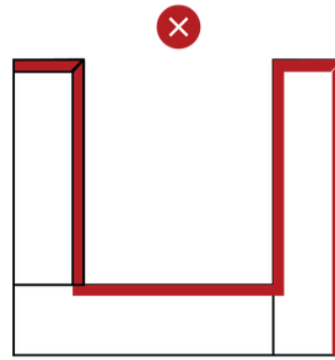

Underside of countertops showing incorrect positioning of lamination strips

Underside of island bar showing lamination strips in place plus an exploded view of the lamination pieces. Island bar laminations should follow the full perimeter of the countertops. If you require a full thickness lamination under the overhang use a separate infill piece as shown here.

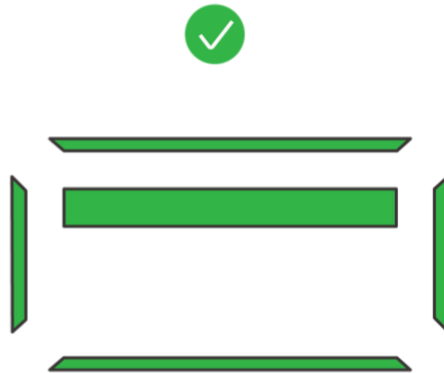
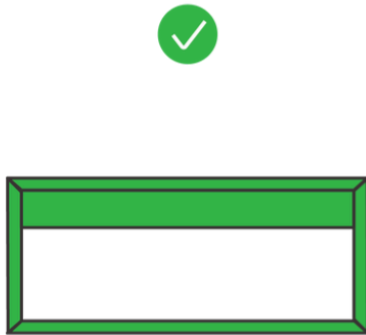

8.4.3 Multilayered Edges

Characteristics of Multilayered Edges:

Multilayered edges are created by adding one or more lamination strips underneath the outer edge of the surface.

Triple or more edges allow for various design possibilities, such as using lamination strips of different thicknesses or colors and recessing one or more of the strips.

This method is commonly used to create the popular double bullnose edge.

Fabrication of Multilayered Edges

- **REDUCE**

Before attaching the lamination strip to the underside of the surface, reduce it by approximately 3 mm ($\frac{1}{8}$ ") behind the edge to ensure a flush joint and allow space for adhesive. Leave a few unreduced sections on the strip to maintain its full height when attached to the surface.

- **CHECK FLUSH JOINT:**

Position the reduced lamination strip against the underside of the surface to ensure a flush joint. If needed, smooth the contact points until the edges are flush.

- **GLUE:**

Attach the lamination strip to the surface with adhesive.

- **CLAMP:**

Secure the strip to the surface with clamps at regular intervals to ensure an even bond and eliminate visible glue lines.

Polish: Once the strip is glued, polish the entire visible edge area.

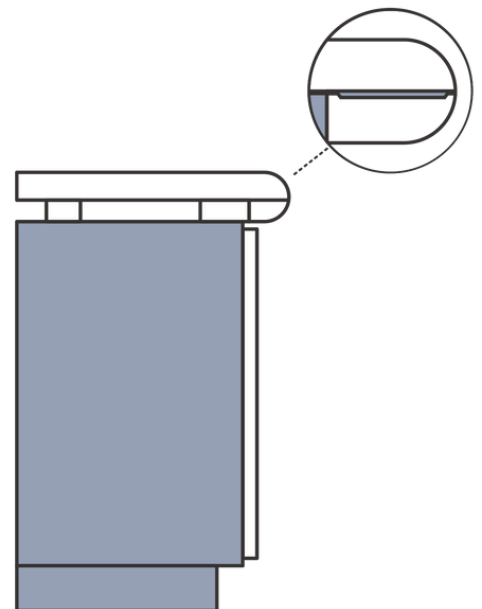



8.4.4 Miter Edges

Characteristics of Miter Edges

- Miter edges allow for the fabrication of edges of any height, independent of the slab thickness. They enable the continuation of a pattern around an edge.
- Miter edges can create various edge profiles of different depths.
- Polishing is only necessary on the visible surface of the miter; the vertical part does not need to be polished.

Fabrication of Miter Edges

CUT STRIP

- Cut a strip from the slab. The strip's width should match the height required for the miter edge.

For miter edges on slabs with prominent designs, cut the slab at the planned miter join to continue the slab pattern.

STANDARD MITER JOIN

- Fabricate miter edges at a 45° angle for maximum strength and a final edge angle of 90°. Angles less than 45° are prone to chipping.
- Distribute adhesive evenly throughout the joint.
- Polish the miter edge to a radius or bevel profile as required.

Avoid joins in the middle of small radii or bevels, as these are more prone to chipping; create a large radius instead.

HIGH-STRENGTH MITER JOIN

- For areas under greater stress, after cutting the 45° angle, slightly reduce the angle on the back part of the miter with a manual tool to create space for adhesive. This technique provides a stronger joint and a flush closure on the visible part of the miter.

DO NOT CREATE ANGLES LESS THAN 45°

Angles less than 45° create a thin wedge at the tip of the miter, which increases the risk of chipping or breaking. Additionally, a larger edge radius will result in more visible joint adhesive.

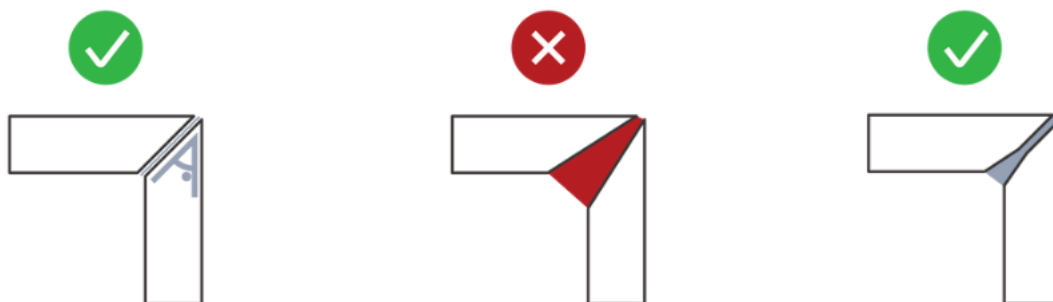

It is recommended to use a miter clamp in order to create an accurate 90° angle, to tighten the joint and prevent the adhesive showing

SHADOW LINE

An alternative is to use a 5 mm x 5 mm shadow line joint. This joint is ideal for waterfall ends that extend to the floor and allows for more movement in the cabinets over time.

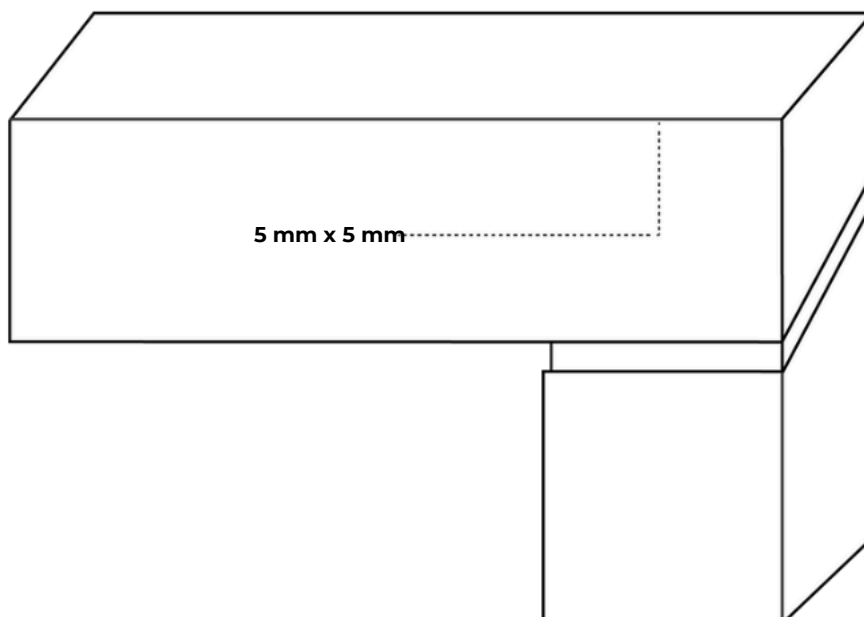

8.5 Polishing Edges

Follow these steps to achieve a polished edge that matches the factory finish of Surfaces by Pacific quartz surfaces.

General Guidelines

- ★ Do not polish the surface face—only the edges should be polished.
 - Ensure the area is clean and free of debris before starting.
 - Use water-cooled tools when polishing to avoid overheating, which could damage the material.
 - Use a polishing drum or bob for polishing rounded or curved inside corners and small cutouts with exposed edges.
 - Each polishing stage should eliminate the marks from the previous stage. Progress through finer grits until achieving a uniform finish.
 - Avoid over-polishing beyond the factory finish on any edge profile.
- ★ For significant material removal, start with a water-cooled diamond grinding wheel before moving to finer polishing pads.
- ★ Manual polishing stones are not recommended for achieving a quality polish.

Methods

Edges can be polished using either the 4-step wet polishing pads designed for quartz or through the traditional multi-step polishing method outlined below:

- Always use diamond polishing pads with water.
- Polish progressively, starting from coarser grits (lower numbers) and moving to finer grits (higher numbers).
- Polish edge profiles gradually, following the detailed steps in the provided tables.



8.5.1 Polished Finishes

Polished finishes are smooth and shiny. Achieve polished finishes using diamond polishing pads. Avoid overpolishing; do not use a 3000 grit pad, as it will make the polished area shinier than the surface.

ACCESSORY	GRIT SIZE
Green diamond polishing pad	60
Black diamond polishing pad	80
Red diamond polishing pad	120
Yellow diamond polishing pad	400
White diamond polishing pad	800
Blue diamond polishing pad	1500

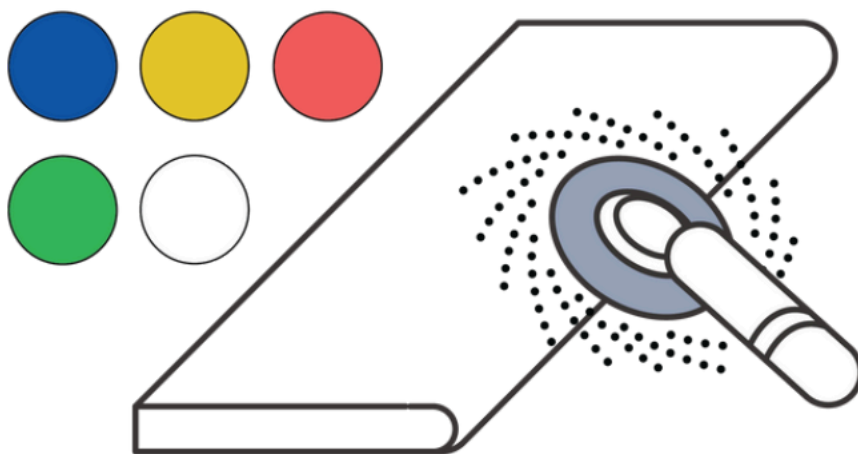

8.5.2 Concrete, Honed/Matt, and Natural Finishes

These finishes are smooth but not shiny. Achieve these finishes using diamond polishing pads up to 400 grit, depending on the desired finish.

ACCESSORY	GRIT SIZE
Green diamond polishing pad	60
Black diamond polishing pad	80
Red diamond polishing pad	120
Yellow diamond polishing pad	400

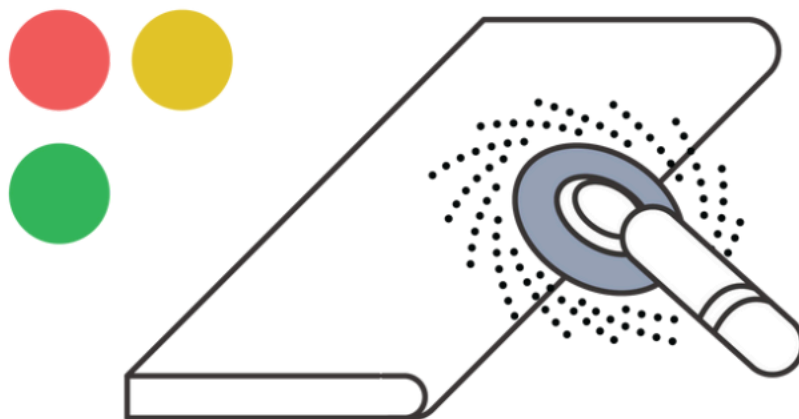

8.5.3 Rough Concrete Finishes

These finishes are slightly coarse with a low gloss. Achieve these finishes using diamond polishing pads and diamond polishing brushes. Ensure to work with the brushes using plenty of water.

ACCESSORY	GRIT SIZE
Green diamond polishing pad	60
Diamond polishing brush	60
	80
	120
	400
	800
	1500

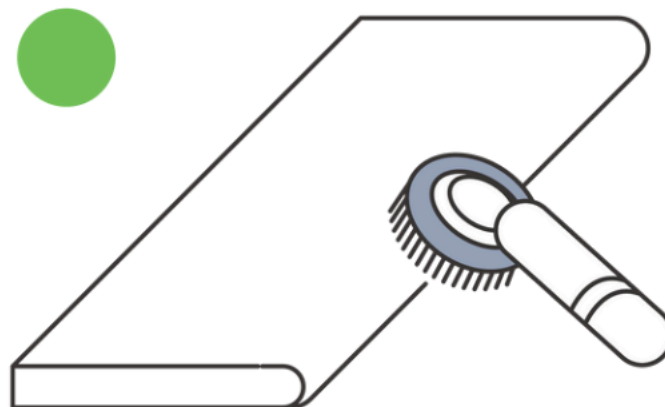

8.6 Support Strips

Glue support strips of Surfaces by Pacific or solid timber to the underside of the edge to elevate and support it, particularly where a laminated edge might obstruct cabinet doors. This also reinforces the edge.

WHOLE LENGTH FRONT AND BACK

Glue the support strips along the entire length of the front and back of the cabinet.

HEIGHT AND WIDTH

The strips should be at least 70 mm (2 3/4") wide and the same height as the part of the lamination strip that protrudes underneath the slab.

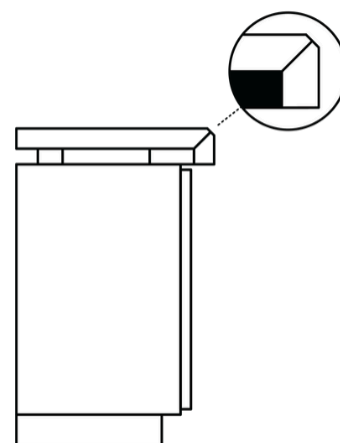

ALIGN JOINS

The support strip should match the length of the surface it is attached to. Joins in the support strips should align with the surface joins.

45° JOINS

Avoid partial support strips, as they create stress points that may lead to cracking on the countertop above. If multiple pieces are necessary for the support strips, make diagonal 45° angle joins and cut the support pieces on outside corners at a 45° angle.

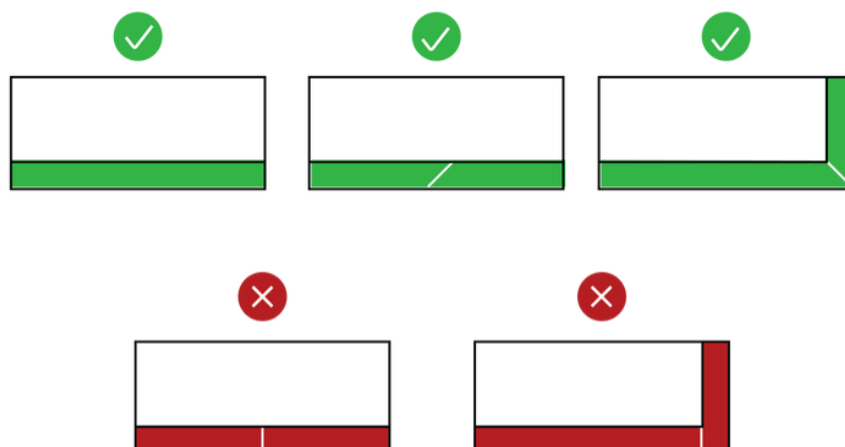



9. Installation

9.1 Preparing the Base Units/Cabinets

Below is technical information and data related to common applications of Surfaces by Pacific products. For other applications, please consult your local distributor.

CABINET REQUIREMENTS

Before installing the surface, ensure that cabinets are complete, stable, level, and capable of supporting the weight of the surface. The cabinets should be securely fastened to each other and to the back wall. Verify that the front and back legs are stable and make full contact with the floor.

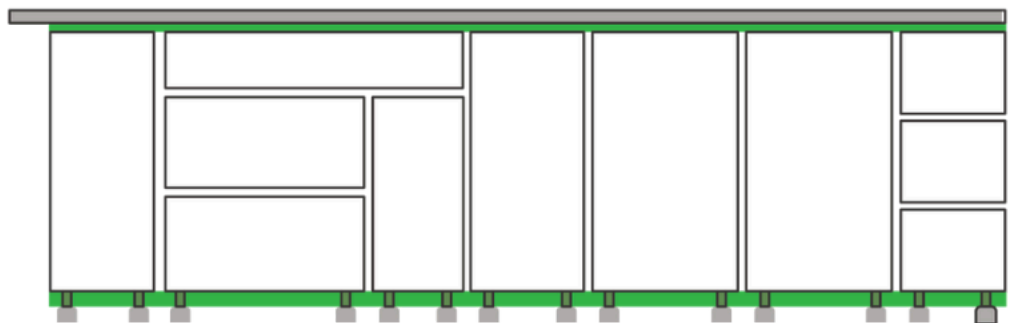

SUPPORT

Ideally, Surfaces by Pacific should be supported on a subdeck. It is also acceptable to use a strong perimeter frame, provided all necessary supports are installed.

For areas larger than 600 x 900 mm (24" x 36"):

- For 12 mm and 20 mm surfaces, use a 15 mm (5/8") plywood subdeck.
- For 30 mm surfaces, use a 50 mm x 25 mm (2" x 1") wooden batten or center spine of clear pine or stronger; a full subdeck is not required.

Provide front-to-back support every 500-600 mm (20-24"). Additional support is required for cabinets wider than 600 mm (24").

For areas with less than four sides (e.g., openings for dishwashers or undercounter refrigerators):

- Provide support every 200 mm (8") for 20 mm
- slabs. Provide support every 400 mm (16") for 30 mm slabs.

In cabinets with cutouts or ovens, install vinyl-wrapped, solid timber vertical rails for additional support, especially when the cooktop or hob cutout is above the oven.

For cutouts longer than 600 mm (24"), provide side-to-side support beams under the surface. Ensure the countertop is sufficiently supported around seams, cutouts, and spaces for appliances such as dishwashers, ovens, and washing machines.

Examples of support include:

- Wooden beams inside cabinets. Upright countertop-to-floor panels.

Support under all countertop seams.

Attach a solid top over undercounter appliances that generate heat to provide both support and insulation. This is not necessary for fully integrated appliances with integral heat insulation, as it may prevent proper alignment with cabinet doors.

DRAWER CABINETS

Drawer cabinets should have a solid top, as vertical rails are not practical.

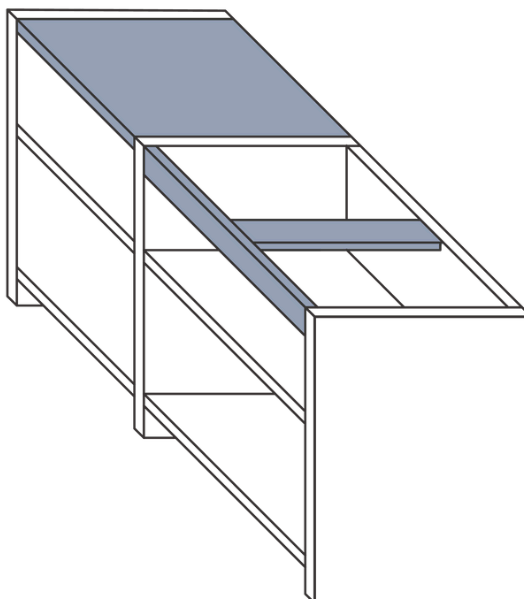

9.2 Countertops

9.2.1 Preparation for Installation

CHECK PIECES IN FINAL POSITION

Place all fabricated pieces of the surface in their final position on the cabinets without using adhesive. Verify that all pieces are the correct size, shape, and orientation relative to the cabinets and walls.

CHECK EDGES AND CORNERS

Ensure that all exposed edges and corners are fabricated and rounded as required.

CHECK LEVEL

Use a spirit level and a long ruler to confirm that the surface is straight and level.

ALLOW FOR EXPANSION AND CONTRACTION

Leave a gap of 1 mm (1/32") per linear meter between straight stretches of the surface and each wall to accommodate expansion and contraction, with a minimum gap of 3 mm (1/8") in any case.

VISUAL INSPECTION

Perform a final visual inspection to ensure the surface meets your satisfaction.

9.2.2 Seaming

PART THE FABRICATED PIECES

Separate the fabricated pieces slightly at the seam.

PROTECT THE CABINET

Place a layer of paper, plastic film, or plastic tape on the cabinet beneath the seam to prevent the adhesive from sticking the surface to the cabinet.

PREPARE ADHESIVE

Prepare a color-matched resin adhesive. If necessary, mix the adhesive with pigments using a stainless steel or plastic spatula to achieve the required shade, or use a precolored methyl methacrylate type adhesive with a dispensing gun.

PURGE THE ADHESIVE

Purge about 50 mm (2") of adhesive from the mixing nozzle to ensure proper mixing when using the precolored methyl methacrylate type adhesive.

CLEAN THE SEAM

Ensure the seam area is free of debris. Clean the edges to be joined with alcohol.

PROTECT EDGES

Apply tape to the edges of the surface to be seamed to prevent staining from adhesives.

APPLY ADHESIVE

Spread a generous amount of adhesive on both sides of the seam. Ensure the X-shaped pattern in the middle of the seam is fully filled with adhesive.

SECURE THE SEAM

Close, secure, and straighten the seam with clamps or a professional seaming clamp to create a smooth, flush surface.

REMOVE CLAMPS

After the adhesive is completely dry, remove the clamps.

REMOVE EXCESS ADHESIVE

Remove any excess adhesive with a scraper or razor blade held at an angle to avoid chipping the adhesive.

FINAL CLEANING

Perform final cleaning with alcohol on a clean white cloth.

DO NOT POLISH

Do not polish seams on Surfaces by Pacific.



9.2.3 Sealing Between the Surface and the Wall

TENSION LEGS EVENLY

If the cabinets are supported on adjustable legs, ensure that all legs are evenly tensioned to maintain stability.

CLEAN SPACE

Clean the space between the surface and the wall.

FILL SPACE

Fill the space generously with a flexible adhesive, such as 100% silicone. Avoid creating grooves in the wall for fixing the Surfaces by Pacific.

PREVENT WATER ENTRY

The silicone adhesive will prevent water from entering the cabinet.

VISIBLE JOINS

For visible joints between Surfaces by Pacific and different materials, use colored silicone, suitable acrylic mastic, or paintable latex caulk.

9.2.4 Attaching Surfaces by Pacific to Cabinets

CARCASS/SOLID TOP

Attach the Surfaces by Pacific to the carcass or solid top using dabs of 100% silicone, placed approximately 300 mm apart.

STAND-ALONE PIECES

Stand-alone pieces smaller than approximately 1 m² (10 sq ft) should be fixed with a suitable flexible adhesive.

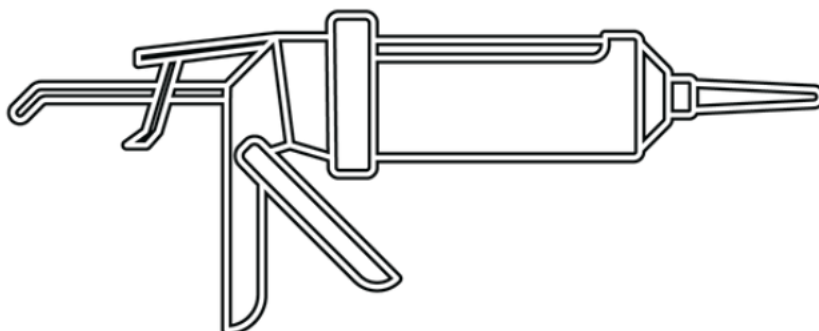

9.3 Sinks

FOLLOW MANUFACTURER'S INSTRUCTIONS

Install, glue, and seal the sink according to the manufacturer's instructions after installing the surface.

USE 100% SILICONE

Seal the sink to the surface with 100% silicone.

PROVIDE FULL SUPPORT

Ensure that the sink is fully supported inside the cabinet, such as by using support rails or legs connected to the cabinet, in addition to being attached to the Surfaces by Pacific quartz.

DO NOT USE SINK CLIPS

Avoid attaching sink clips or any mechanical fasteners directly to the Surfaces by Pacific quartz.

Ensure that enough space is left underneath the cutout for access and for any parts that need to be installed underneath the surface, such as the sink, bolts, soap bottle, etc.

9.4 Cooktops/Hobs

FOLLOW MANUFACTURER'S INSTRUCTIONS

Install cooktops/hobs according to the manufacturer's instructions, paying close attention to insulation requirements and materials.

AVOID COOKTOPS/HOBS ABOVE DRAWER UNITS

Try to avoid installing cooktops/hobs above drawer units, as this limits the use of vertical rails and weakens the support structure under the countertop. If unavoidable, drill five holes of 80 mm (3 1/8") diameter in the base of the cabinet underneath the cooktops/hobs to allow for ventilation and cooling. If there are shelves, ensure that space is left at the back for ventilation.

INSTALL RAISED COOKTOPS/HOBS OVER

CUTOUTS Ideally, raised cooktops/hobs should be installed over cutouts for ventilation and heat dissipation. If a cutout is not created, drill five holes of 80 mm (3 1/8") each in the surface underneath the cooktops/hobs and in any cabinet tops if present. Please note that the PITT cooking system must not be installed in Surfaces by Pacific quartz.

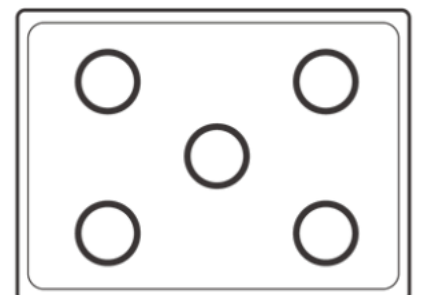

9.5 Utility Rooms

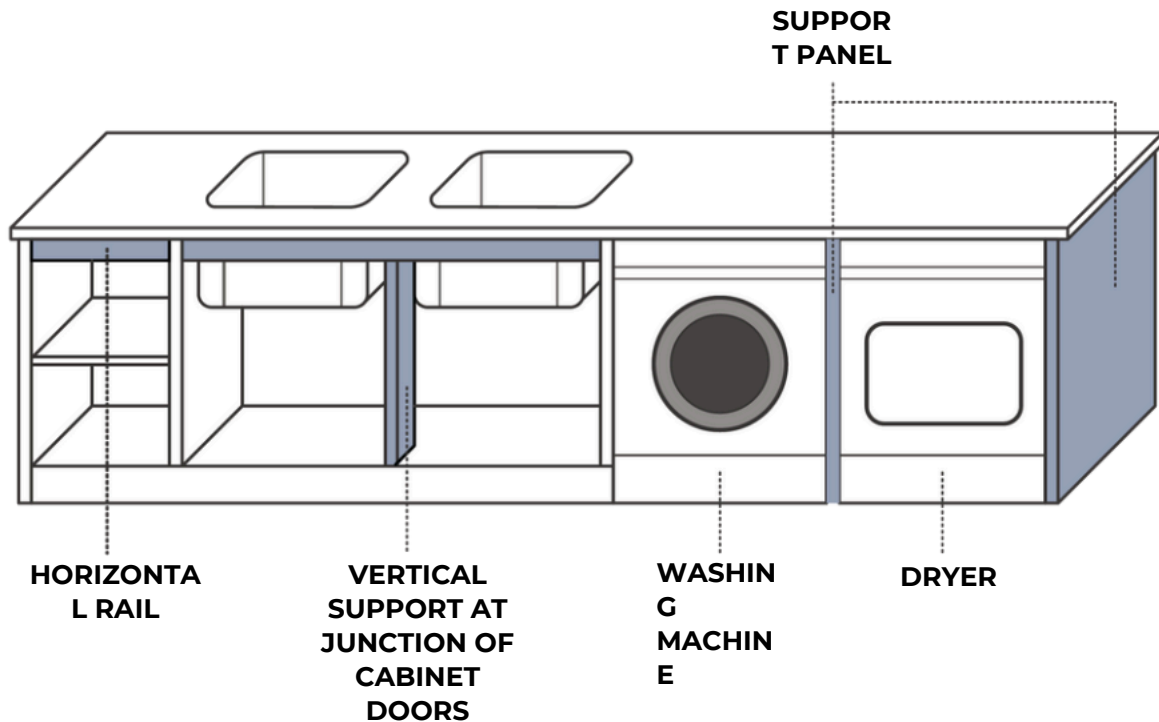

Utility Sinks

Utility sinks require additional reinforcement and support. The dual 45-liter (12-gallon) sink mentioned above, which requires a wide cabinet to accommodate it, has a total capacity of 90 liters (24 gallons), meaning it could potentially hold 90 kg (200 lb) of water. This is comparable to a person standing on the top in an area with a large cutout.

Washing Machine and Dryer

These appliances generate significant heat. Some vent through the front, while others vent through the back; some may require ducting.

When installing these appliances side by side, place a support panel between the appliances and either a support panel or cabinet on both sides.

Install a solid plywood top over these appliances to protect the surface from the heat.

These principles also apply to wine refrigerators.

9.6 Accessories

Accessories can be attached to Surfaces by Pacific quartz using mechanical anchoring, adhesive anchoring, or a combination of both. Use a combination of these methods to securely attach heavy accessories to Surfaces by Pacific quartz.

9.6.1 Attaching Accessories Mechanically

Drill a hole of the required size and shape through the material.

When the back of the slab is accessible (e.g., sink surrounds, countertops, and vanities), slot the accessory through the hole and secure it to the back of the slab using the appropriate nut or fastener provided by the accessory manufacturer.

Avoid applying excessive pressure when tightening the nut, as this could damage the surface. Use a washer or other pressure disperser to prevent creating pressure on a small area.

When the back of the slab is inaccessible, attach the accessory to the substrate behind the material using anti-corrosive screws or bolts of the appropriate size and strength, with the screws or bolts slip-fitted through the material.

For both types of mechanical attachment: For holes up to approximately 40 mm (1½"), leave a minimum of 50 mm (2") between the edge of the hole and the edge of the surface/cutout to maintain the surface's strength. For larger holes, the minimum remaining surrounding surface must be proportionately larger.

Do not attach mechanical fasteners (screws, nails, etc.) directly to Surfaces by Pacific quartz.

If securing items to the surface is necessary, use flexible adhesive only.

9.6.2 Attaching Accessories with Adhesive

Most accessories come with an integral self-adhesive pad, which can be attached directly to the surface.

If the accessory does not include a self-adhesive pad, attach it to the surface using an appropriate adhesive, such as 100% silicone.

9.7 Overhangs

An overhang is a surface that extends beyond the edge of the supporting structure, such as a countertop extending past the edge of the supporting cabinet.

REINFORCEMENT

Additional strength can be achieved by laminating the edge of the overhang and attaching another slab of the same thickness underneath. In this method, the bottom slab is attached back to back beneath the surface so that the polished side is exposed underneath.

PERMITTED OVERHANG

The fabricator is responsible for determining the required support for the overhang. For all installations, the unsupported overhang must not exceed $\frac{1}{3}$ of the total surface depth.

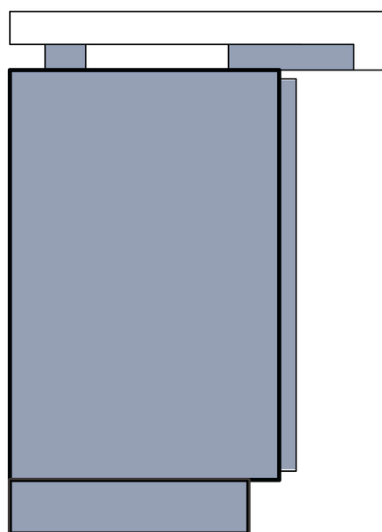

20 MM THICKNESS SLABS	30 MM THICKNESS SLABS	SUPPORT REQUIRED
<300 mm (12")	<400 mm (16")	No additional support required
300-500 mm (12-20")	400-600 mm (16-24")	Support bracket at 600 mm (24") interval
>500 mm (20")	>600 mm (24")	Leg, column or panel at 600 mm (24") interval

Overhanging surfaces of 12 mm require more support than 20 or 30 mm. Reinforce 13 mm overhangs with strips of Surfaces by Pacific' or a metal frame.

OVERHANG SUPPORT GUIDELINES

If the outside corner of a two-direction overhang extends beyond the recommended unsupported overhang limit, provide additional support using flat brackets as shown in the diagram below, in addition to the recommended support.

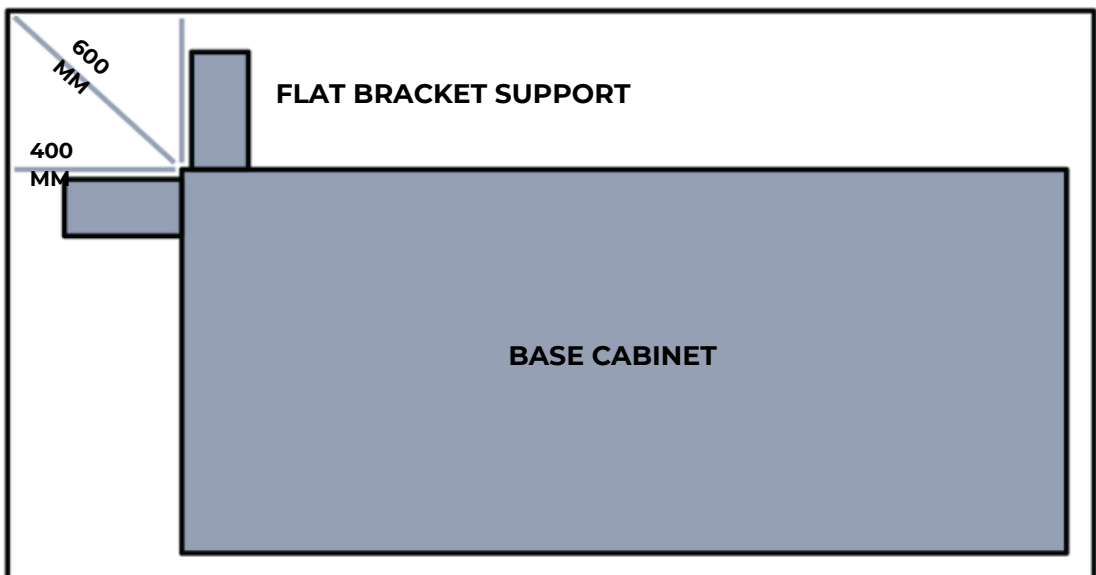

9.8 Tabletops

- When installing a Surfaces by Pacific quartz as a freestanding tabletop, design the base area of the leg or legs to securely support the tabletop.
- Spread a suitable flexible adhesive evenly on the top surface area of the supporting leg or legs. Ensure that the adhesive covers a sufficient area to securely hold the surface.
- Tabletops can also be created on a frame as shown below.

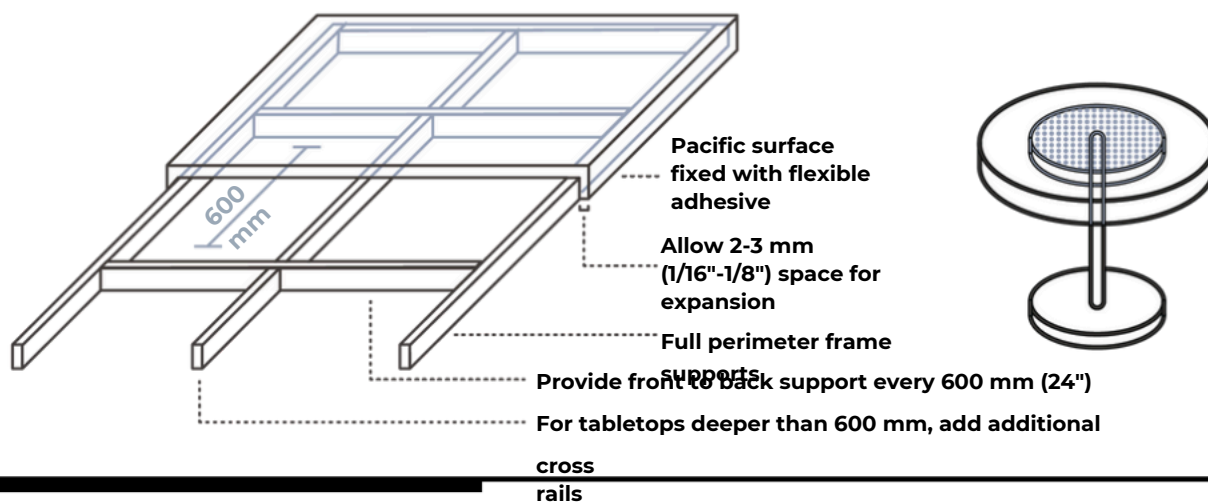

9.9 Finishing Touches

POST-INSTALLATION CLEANING

Thorough post-installation cleaning, especially of dried adhesive or silicone residue, is crucial to minimize time-consuming and costly remedial work. For detailed instructions on removing dried adhesive and silicone, refer to Section 10, Care & Maintenance.

PROTECT SURFACE FROM OTHER WORK

If further construction work is to be performed at the job site after the surface installation is complete, ensure the Surfaces by Pacific quartz is properly protected by covering the entire top with corrugated cardboard or another protective material.

WARN OF POTENTIAL DAMAGE BY OTHER TRADESMEN

Inform the customer that any subsequent tradesmen must NOT use the new countertop as a workbench, step, or standing platform, and that those using strong solvents or adhesives must exercise caution.

OBTAIN CUSTOMER SATISFACTION IN WRITING

It is strongly recommended that customers provide written confirmation of their satisfaction with the material and workmanship at the end of the installation to protect the fabricator from damage caused by others.

PROVIDE WARRANTY AND CARE & MAINTENANCE INSTRUCTIONS

Ensure that the Warranty and Care & Maintenance details are provided to the customer.

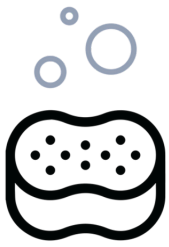

10. Care & Maintenance

GENERAL CLEANING GUIDELINES

Surfaces by Pacific recommends using water and a mild, non-abrasive detergent or a high-quality spray-and-wipe cleaner on a soft cloth or non-abrasive scourer for routine cleaning of Surfaces by Pacific quartz. Refer to Section 10.1, Table 1: Approved Cleaning Materials.

For more information about everyday cleaning, please visit our website at <https://pacific-surfaces.com/>.

SURFACE FINISHES

Finishes other than Polished may require additional daily maintenance due to their unique patterns and finishes.

SCRATCH RESISTANCE

Surfaces by Pacific quartz is scratch-resistant. However, avoid using sharp objects like knives or screwdrivers directly on the surface—always use a cutting board.

HEAT RESISTANCE

Sudden and extreme heat, as well as prolonged or direct heat, can damage all natural stone surfaces, including Surfaces by Pacific quartz, especially near edges. Always use trivets or similar protective items for hot cookware or cooking units, such as electric frying pans, crock pots, or toaster ovens, rather than placing them directly on the quartz surface.

DARK SURFACES

Dark surfaces, objects, and furniture are more prone to showing fingerprints and other signs of daily use compared to light surfaces. Therefore, dark Surfaces by Pacific may require more frequent maintenance.

Dark quartz models, like all dark surfaces, are more sensitive to scratch marks. Protect the surface from sharp objects by using a cutting board.

Limescale may be more visible on dark surfaces than on light ones, so avoid leaving liquids to dry on the surface.

Cream-textured cleaning products are not recommended for dark surfaces.

10.1 Stain Removal for Fabricators

These guidelines are for treating specific stains and are not intended for routine cleaning. Use with caution.

GENERAL FACTS

- Most food stains can be removed.
- Chemical stains may be permanent, depending on their properties.

GENERAL STAIN REMOVAL GUIDELINES

Gather as much information as possible about the countertop's use and the cleaners used before attempting to address the stain.

Start with mild cleaners and progress to stronger ones if needed. Cleaning materials, from mild to strong, include:

- Dishwashing liquid
- Mild detergent
- Cream-textured cleaning products
- Powdered cleaning products

Test cream-textured and powdered cleaning products on an inconspicuous area first to ensure they do not damage the surface.

Be patient—some cleaning procedures require time.

IDENTIFYING STAIN TYPE

- Most stains and marks are either lighter or darker than the surface.
- Darker marks typically indicate something on the surface, such as adhesive, oil, wine, coffee, blood, rust, silicone, sealer, or metal.
- In severe cases, darker marks might be serious burns, which generally cannot be removed.
- Lighter marks usually indicate that something has been removed by abrasion, such as resin, pigment, or patina. If resin or pigment has been removed, the damage is usually permanent.
- Lighter marks can also be due to grout, caulk, or paint residue on the surface.

STAIN REMOVAL

General cleaning instructions:

1. Apply the appropriate cleaning material to a DRY paper towel.
2. Gently rub in a circular motion (similar to waxing a car) over an area of about 4 sq ft / 0.4 m² of the surface.
3. Reapply cleaner to the paper towel and rub another area of the same size.
4. Repeat this process over the entire countertop.
5. Allow the cleaner to stand for approximately 5 minutes as it begins to dry.
6. Reactivate the cleaner with water and gently remove it in a circular motion.

Food and beverage stains, magic marker, natural patina, and stubborn stains

- Use an approved spray/gel cleaning material from Table 1: Approved Cleaning Materials, such as Soft Scrub® with Bleach Cleaner Gel.
- For Concrete, Honed, and Rough Concrete finishes, you may also use a cream-textured cleaning material from Table 1: Approved Cleaning Materials, such as Soft Scrub® Cleanser with Bleach.

Rust stains and metal marks

- Place a small amount of Bar Keepers Friend® Cleanser (powder) or oxalic acid on a damp paper towel. Gently wipe in a circular motion.
- Rinse thoroughly with warm water and dry with a paper towel.
- Be very gentle with this method, as it may damage the surface finish.

Silicone residue, buildup (long-term) stains, or mild chemical stains such as tape marks

- Use denatured alcohol and an oxalic acid-based cleaning material such as Bar Keepers Friend® Cleanser (powder). Wear rubber gloves for this procedure.
- Pour a small pile of the powder in the center of a paper towel.
- Pour denatured alcohol on the powder and mix into a toothpaste consistency.
- Gently rub in a circular motion (similar to waxing a car) over an area of about 4 sq ft / 0.4 m² around the affected area for no more than one minute.
- Wipe the mixture away with water and/or a glass cleaner such as Windex® to neutralize the chemicals.
- Repeat the process over the entire surface if it is over 6 months old or if sealer was applied.
- If dark color transfers onto the paper towel, it indicates that the process is working, so repeat until the stain is gone.

Dried adhesive, chemical stains, and chemical patina*

- Use lacquer thinner and an oxalic acid-based cleaning material such as Bar Keepers Friend® Cleanser (powder). Wear rubber gloves for this procedure.
- Pour a small pile of the powder in the center of a paper towel.
- Pour lacquer thinner directly on the powder and mix into a toothpaste consistency.
- Gently rub in a circular motion (similar to waxing a car) over an area of about 4 sq ft / 0.4 m² around the affected area for no more than one minute.
- Wipe the mixture away with water and/or a glass cleaner such as Windex® to neutralize the chemicals.
- Repeat the process over the entire surface if it is over 6 months old or if sealer was applied.
- If darker color transfers onto the paper towel, it indicates that the process is working, so repeat until the stain is gone.

PATINA

Patina naturally forms on all quartz products over approximately 6 months of use when using mild cleaners such as soap and water or Windex®. This effect is less pronounced if bleach-based cleaners are used regularly.

Patina causes all colors to appear slightly darker and shinier. It only requires deep cleaning if its removal creates a differently colored area on the surface (see section: Food and beverage

stains, magic marker, natural patina, and stubborn stains).

Surfaces by Pacific quartz is sold without patina.

WHAT TO AVOID

- Do not allow your Surfaces by Pacific quartz to come into contact with strong acids, alkalis, oxidizers, or similar materials, regardless of pH.
- Avoid using harsh cleaning products such as oven/grill cleaners, dishwasher polishing agents, lye, caustic soda, paint strippers, or any products containing trichloroethane or methylene chloride.
- Do not use wax, sealers, or other materials that may leave a film on the countertop.
- Use of acetone is forbidden on Surfaces by Pacific quartz. Alcohol is recommended for cleaning during installation.
- Avoid abrasive scourers or Mr. Clean Magic Eraser as they can damage the finish/sheen of your surface.
- If the surface comes into contact with any potentially damaging products, rinse immediately with plenty of water.
- After cleaning, thoroughly rinse off any cleaning materials with water.
- If using a cleaning product not on our list of recommended products, first test it on an inconspicuous area to ensure it does not damage the surface.



11. Environment, Standards & Certificates

At Surfaces by Pacific, minimizing our impact on the environment is a top priority for management, involving all employees and departments to ensure our leadership in sustainability.

We aim to create durable, low-maintenance products that contribute to healthier environments and more efficient use of material resources:

LOW MAINTENANCE – Our surfaces require minimal upkeep and significantly reduce the need for sealants, cleaning materials, and detergents.

HIGH PERFORMANCE AND DURABILITY – Our quartz surfaces are designed to be long-lasting and durable, providing both improved life cycle costs and enhanced investment value.

LOW-EMITTING PRODUCTS – Surfaces by Pacific quartz meets stringent product emissions standards with minimal impact on indoor air quality.



ISO 9001-2015

Certification based on the standard published by the International Organization for Standardization titled "Quality management systems-Requirements".

NSF

Material suitable for food contact. NSF assures that a certified product, material, component or service complies with the technical requirements of the referenced standard.

CE

CE marking is a certification mark that indicates conformity with health, safety, and environmental protection standards for products sold within the European Economic Area (EEA)

Kosher Certification

We comply with a strict policy of kosher food laws, including cleanliness, purity and quality.



12.Disclaimer

This Guide is intended for use by individuals with expertise, professional experience, and technical skills, at their own discretion and risk. Surfaces by Pacific accepts no responsibility and disclaims all liability for any harmful effects resulting from the fabrication and installation of our products. The information and recommendations contained herein are based on data believed to be correct as of the publication date, based on our knowledge, experience, and that of our professional partners, reflecting common events encountered with Surfaces by Pacific quartz slabs.

While every effort has been made to ensure the accuracy of this document, we assume no responsibility for errors or omissions or for damages resulting from the use of information contained herein. We shall not be liable for any loss of profit or other commercial damage caused or alleged to be caused directly or indirectly by reliance on this document.

Due to the varied situations that may arise when working with Surfaces by Pacific quartz slabs, the instructions in this Guide should be regarded as general principles. Professional judgment should be exercised before performing any actions. A prior trial is recommended before undertaking any new procedures. Surfaces by Pacific representatives are available to answer any questions.

This Guide should not be considered as a comprehensive list, interpretation, or summary of any laws, standards, rules, orders, or safety requirements and should not be relied upon solely. Fabricators and installers of Surfaces by Pacific quartz slabs must be familiar with relevant local laws and standards, including, but not limited to, Occupational Health and Safety laws and environmental protection laws. It is the user's responsibility to ensure compliance with all applicable laws and regulations.

No guarantee or warranty of any kind, express or implied, is made regarding merchantability, fitness for a particular purpose, or otherwise.

NOTICE - HAZARDOUS SILICA DUST

Please be reminded that Surfaces by Pacific products contain crystalline silica (up to 90%). Processing these products generates crystalline silica dust. Prolonged or occupational inhalation of crystalline silica dust can cause silicosis (an incurable, progressively disabling, and sometimes fatal lung disease) and may cause other serious diseases. Do not process this product without implementing all safety measures.